

UR FOG



Notification of successful installation

Hereby informs that UR FOG machine, model
has been connected to the alarm system at:

Company Name	
Address	
Referent	E-mail address
Phone number	Mobile number

The fog machine generates a dense fog when an intrusion occurs to impede the visibility to the intruder.
The fog is safe for people, animals, things and food.
This notification has been sent or delivered to:

Firemen	
Referent	E-mail address
Phone number	Mobile number
Public security	
Referent	E-mail address
Phone number	Mobile number
Private security	
Referent	E-mail address
Phone number	Mobile number

AUTHORIZED INSTALLER:

PLACE: DATE:

SIGNATURE AND STAMP:

*UR FOG S.r.l. Sede legale / Legal Office : via Giacinto Collegno n°11 - 10143 Torino - Italy
Sede operativa e magazzini / Operation and delivery to : via Toscana n° 38 - 10099 San Mauro T.se (Torino) - Italy
C.F. / P. Iva 10724850010 - Reg. Imprese TO - 1157030 - Cap. Soc. Euro 10.000 int. versati
Tel. +39 011 0133037 - Fax +39 011 0133005 - e-mail : amministrazione@urfog.com*

**N.B. Ask for the PDF module
writing to: support@urfog.com**

UR FOG

Installation and use manual



**mod. FAST 03 1C PRO PLUS
mod. FAST 03 2C PRO PLUS
mod. FAST 02 2C PRO PLUS**
ENGLISH MANUAL



The warranty of **UR Fog** is two years and is handled directly from the dealer or authorized installer, so please contact your supplier to take advantage of warranty with the copy of the purchase document that contains the serial number of the machine. Not included in the warranty: moving parts and/or damages depending on the incorrect use unless it is found a manufacturing defect in origin. Liquid and cylinders are not covered by warranty.



BY BREAKING THE SECURITY LABELS AND THE OPENING OF THE MACHINE YOU WILL ACCEPT WHAT IS WRITTEN ON THIS MANUAL AND ON THE WEB SITE: **www.urfog.com**



UR Fog srl, Via Toscana n°38 - 10099 - San Mauro Torinese - Italy
Tel 011/01.33.037 Fax 011/01.33.005
support@urfog.com.

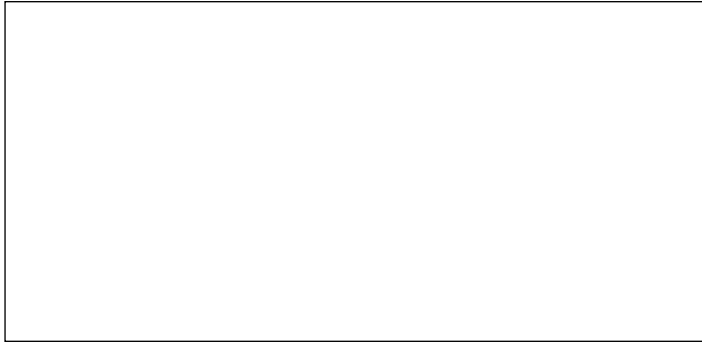

Legal office: Via Giacinto Collegno 11 - 10143 - Torino - Italy

RESELLER/INSTALLER STAMP
(company to contact for the warranty)

Serial number.....

Date of installation.....

Signature of installer



At the end of the installation, write down the identification number of the machines, the date of the installation and sign in the dedicated spaces.

Thank you for purchasing UR Fog product.

The great patented technological innovations such as the liquid injection system, the disposable cylinders, the fact that they don't need to be refilled, the ecological and economic system for the complete emptying of the cylinders, together with the heating system, all of them make the PRO PLUS fog generators the best fog devices with the best performance in the security market.

- Reliable: There are no high pressure pumps which lose fluid or tend to stop working.

There are no high pressure pumps that must be tested periodically.

Double cylinders technology is guaranteed to work in any condition.

- Competitive: Complete use of cylinders liquid avoiding any waste of liquid thanks to pressure control.

Low power consumption. Fast and powerful.

- Simple: Machine easy to install and able to be integrated to any existing alarm system.

The fog generated by **UR Fog** does not create particular problems or injuries for a human being for a short stay in a fogged room if the system is used according to the manufacturer's recommendations. Generated fog is certified as safe for people and animals from an authorized international certification company and is proved that it does not leave any residual. **UR Fog** systems are certified respecting European laws and regulations. Any certifications required in specific countries are a responsibility of the distributor of that specific country. The documents related to certifications can be requested by mail to support@urfog.com. It is not guaranteed by the manufacturer the use of **UR Fog** system in the presence of objects that may be damaged anyway by the contact with substances based on glycol, water and alcohol. Any employee or worker that may be exposed to fog must be warned in advance and must be checked for any allergy to the substances listed above. At the date of printing of this manual it has never been pointed out any problem related to any allergy. **UR Fog** is in no way responsible for any damage or condition of use that has not been required and specifically approved by any specific written request prior to the installation of its products. For fog fluid please refer to **UR Fog** fluid safety data sheet published on the website and carefully read it at **www.urfog.com**. Contact a doctor if for any reason you swallow fog fluid or if after contact with eyes or skin you have any kind of reaction, and in any case wash it immediately with water and soap. Do never stay for a long time in a room filled with fog. Do not use charged cylinders that are not the ones suggested by **UR Fog** and never try to recharge them, they are made for a single use. Follow your national rules for the dispose of empty cylinders. Keep **UR Fog** cylinders out of reach of babies and animals. The nozzle may be hot and touching it may cause burns. Do not look directly into the nozzle. Never use **UR Fog** products for any purpose that is not related to protection from thief or robbery (the choice of the conditions of use in case of robbery will be suggested by your security consultant). Never use different fog fluids or add any other substance into the cylinders. Do not use or keep charged **UR Fog** machines in vehicles and do never transport **UR Fog** before 24 hours since it has been shut off. During transport it must be not armed.

4 INSTALLATION TIPS FOR FOGGING SYSTEMS



Please observe the following instructions for installing **UR Fog**:

1. The machine must be installed avoiding to obstruct escape routes.
2. Verify the fog does not limit the visibility near: stairs, landings, moving objects that may cause: falls down, injuries or any damage to persons.
3. Do not look directly into the nozzle. Do not add any other substance into the cylinders.
4. The nozzle may reach high temperatures, touch it may cause burns.
5. When **UR Fog** produces fog avoid staying closer than 1 meter from the machine.
6. When **UR Fog** is armed avoid staying closer than 50 cm from the nozzle.
7. Before testing UR Fog, remember to report it in advance to the firefighters in your area to avoid false alarms.
8. Remember to put warning labels about the presence of **UR Fog** on the windows.
9. Report its installation to the firefighters in your area and eventually to other institutions if needed.
10. It is necessary to add an external switch to separate the fog generator from the alarm system and it should be activated before the maintenance to avoid that input tests, for example, can activate the fog generator.
11. Never direct the fog jet towards an object or a wall less than 2 meters away and if possible increase the suggested minimum distance. Thanks to the power of the jet, **UR Fog** reaches and exceeds more than 10 meters away in the first 3 seconds from the point where the machine is installed.
12. Setting the shooting time interval between the minimum and maximum shown in the time table, avoid "overshooting" even if the produced fog is dry and generally doesn't leave residue. A shot that goes far beyond the recommended seconds can create a residue problems in the room.
13. **UR Fog** continues to be effective for up to 2 hours without 220V and 110V main power thanks to the insulation system which maintains the temperature in the heating system.
14. Install at an height of about 2,5 meters not to let it be reached, avoiding possible tampering.
15. Install with a maximum inclination of 20°.
16. Do not move the machine when it is still hot.
17. The main body of **UR Fog**, which has the heating system enclosed inside a metal frame, should not be opened unless by specific and authorized service centers. Do not open and touch for any reason the insulation before 24 hours **UR Fog** has been shut off. The internal part may reach really high temperature.
18. Do not activate the **UR Fog** machine before the installation is completed.
19. Insert the cylinders as the last procedure and verify the anti-tampering function.
20. When the installation is finished, always test the system.
21. From the moment of **UR Fog** activation, at least one hour is necessary to reach the minimum temperature needed for the fog shooting.
22. Install **UR Fog** avoiding any obstacles in front of it which can prevent the spreading of the fog.
23. The external temperature of **UR Fog** can change from room temperature to 50 °C.
24. The tip of a stranded conductor should not be soft-soldered where the conductor is subjected to contact pressure.
25. The **UR Fog** machine should not be exposed to water spray or dripping.
26. Request to **UR Fog** or its distributors to take part in courses for installers to ensure the optimal installation of the equipment.

	Wiring error	Verify that the alarm, once activated has tension on connectors of at least 12 V between GND(5) + SHOOTS(4)
BLUE LED is flashing The buzzer emits a continuous sound BLUE and RED LEDS are flashing alternately	Overvoltage power line (110/220 V)	Try to reset. See paragraph 13 In case of unsuccessful restore the PCB can be damaged, contact the assistance service.
	Overtemperature of the PCB	Check there is a sufficient ventilation around the machine. See paragraph 15 To reset see paragraph 15
	Disturbance/ interference or potential differences between devices	In the case of strong interference (lightning) can occur a thermocouple reading error, make a reset. See paragraph 15. In case of unsuccessful restore can be occurred a potential difference or a fault. In large size plants or with more than on fogging system connected with the same central, in rare situations, it may occur that there are potential differences between the equipments and it could be necessary to uncouple.
	Error in the thermal loop	Possible fault of: thermocouple, resistance or fuse cable. Don't try to repair Contact the assistance service center.
Impossible to arm the machine BLUE LED doesn't switch on	Wiring error	Check on the terminal with a tester that when the alarm system is tuned on there is a minimum voltage of 11 V between - GND (5) + ARM (3).
Cannot arm, BLUE LED doesn't become on	Wiring error	Test the terminal that there is a minimum voltage of between 11V - GND (5) + ARM (3), when the anti-theft system is activated
When you press the reset cylinder's button you don't hear the sound of the buzzer, the frontal LED are flashing but the RED LED does not reset	The Jumper P3 is in the "SET" position	 Warning in this case shooting time is reset to zero Cylinder reset - Paragraph 13 Shooting time setting - Paragraph 11
The cylinder does not enter	The plate is raised	Pressure down and then pull
The cylinder doesn't go out	The cylinder is stuck in the valve	Pressure down and then pull
Setting the shooting time, the buzzer does not sound and the LEDs do not flash	The jumper P3 stands in the "RESET" position	See the setting mode of the shooting time at paragraph 11

DEFECT FOUND	POSSIBLE CAUSE	POSSIBLE SOLUTION
When you connect the machine you hear a relay clicking cyclically	not a fault	When the machine is cold or has just emitted fog, until the exchanger has reached the working temperature, a relay is activated with the triac to decrease the consumption.
When you connect the generator you don't hear the clicking relay	As soon as the PCB is switched on, the microprocessor makes a diagnostic check	For the duration of the test, even GREEN LED are flashing, the exchanger is not activated. Wait for 2 minutes.
	GREEN LED switched on and fix	The heating exchanger has reached the temperature, so the relay is not activated anymore, but just occasionally.
	GREEN LED switched off	There is not 110/220 V power supply, check the mains on the input terminals of power supply and wait for 2 minutes.
When you arm the machine you hear an internal buzz, like a motor	The compressor is checking that there are no obstructions in the circuit of fog emission	When the machine is armed, for 15 minutes the compressor will monitor the nozzle. After this time it will deactivate automatically: if the fogging system is disarmed, the compressor will go on with it reaches 15 minutes. If the machine is disarmed and then armed again, the count will start again from zero.
When you arm the fogging system, a little fog flow goes out from the nozzle even if the machine has never shot before	During testing phase in the factory, we also test the quality of fog in all produced systems, a little quantity of the fog liquid remains in the ducts	This emission occurs just at first activation, it will decrease visibly with any activation, until disappearing completely. After an eventual disassembly and reinstallation or after the transport of the machine, with the first activations a little flow of fog can occur again.
The 3 frontal LED are flashing and the buzzer emits 1 beep per minute	The tension on +12 V input is too low or too high	Check the external power supply or the alarm unit
The buzzer emits 2 beep per minute	Low batteries but possible shot	Replace batteries - See paragraph 14
The buzzer emits 3 beep per minute	Low batteries but possible shot	Replace batteries - See paragraph 14
The buzzer emits 10 continuous beep per minute	Batteries not present	Insert batteries
	False contact in the battery case	Move the batteries, turn them
	Connector not inserted correctly	Remove and reinsert the connector
	In any case it is useful to use a tester to verify the presence of voltage on the battery case	
The machine is armed (BLUE LED ON) but doesn't shoot	The front RED LED is on	Cylinders reset has not been made Reset as described in paragraph 13 Cylinders are empty-Change the cylinders as described in paragraph 13
	The front GREEN LED flashes	The heat exchanger has not yet reached the minimum temperature of shooting, wait for the led to stop flashing (standard heating time: 60 min.)
	The machine doesn't shoot immediately after arming	For safety reasons and to avoid false fog emissions during power on, when the machine is armed, it becomes operative only after 20'. After this time, the emission is instantaneous.

	FAST 03 PRO PLUS	FAST 02 PRO PLUS
Weight without tanks	11,8 KG	15,0 KG
Max fog emission in a single shot	200 m ³	400 m ³
Total fog emission capacity	900 m ³ in 1C version and 1800 m ³ in 2C version	1800 m ³
Fog tanks capacity	2 x 600 ml (1 x 600 ml in 1C version)	2 x 600 ml
Working time without mains power	2 hours 30 minutes	2 hours
Max power on heating system	300 W	300 W
Average power consumption "during heating"	270 W	270 W
Heating time	about 50 minutes	about 2 hours
Maximum consume at 12 V	42 W	45 W
Maximum power consumption at 12 V	500 mA	500 mA
Average batteries lifetime	Pb 2 Ah 12V	Pb 2 Ah 12V
Door tamper	Tamper screw	Tamper screw
Anti-tear off and anti-shift	Accelerometer	Accelerometer



In 1C version, the "empty" signal doesn't mean only that the cylinder is empty, but also warns you that the system is in reserve. For this reason is very important to make the "reset" only when you actually exchange the cylinder, or you will lose the seconds counting. (See paragraph 13)

WARNING :

- Loosened ferrule can cause dropping
- Do not disconnect the machine immediately after the shot
- Change battery every 2 years
- Change the cylinder as soon as the "empty" signal appears



It is always recommended to fix the fog generator to a wall even when it is placed on a flat surface. The optional bracket, mainly recommended for ceiling installation, can also simplify standard installation, by allowing to use back holes for the passage of cables. Remember to use the fixing screw placed in the cylinders compartment.

Always verify that the bracket or the support surface are suitable for the weight of the machine. It is suggested not to install the machine behind walls in a limited closed area without a specific ventilation, in order to prevent a possible overheating.

CAUTION: to avoid injuries please securely fix the fogging machine to the wall according to the installation instructions. In case of installation behind a wall, it is possible to request a nozzle extension of 7 cm.



After removing the machine from the package, unscrew the two screws that stop the right side panel and remove it.

Remove tamper screw and shell screws from inside.

At this point it is possible to remove frontal shell and see electronic circuit, from here on called PCB.



The cylinders supplied with the equipment are intended to be used only for a vertical (standard) installation. In case of horizontal installation, please refer to your authorized reseller/distributor to get the appropriate cylinders. It's necessary to insert the cylinders with the black plastic plug.

To open the additional compartment in the lower part, it is necessary to remove cylinders compartment's door and take off the frontal shell, unscrew and remove the screws below.

The screw in lower left part of cylinders compartment's door is longer than the others and its removal activates the tamper output.

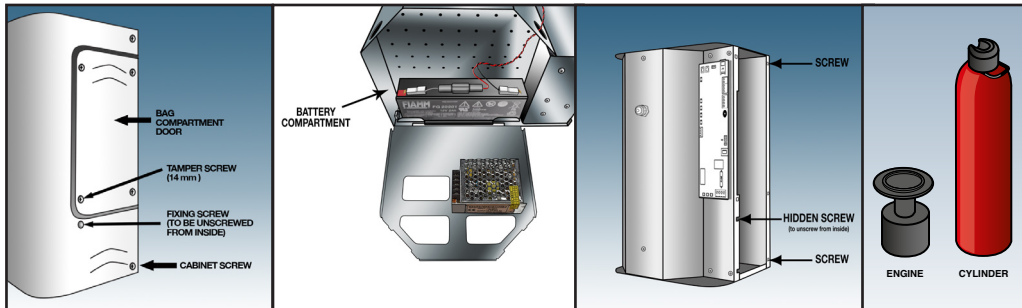

TUBE FOR CABLES TO INSERT IN THE TERMINALS

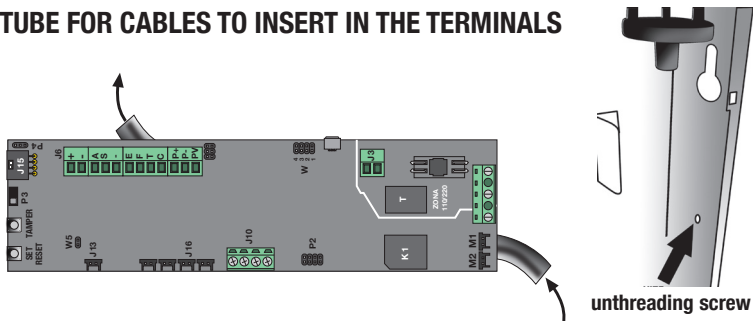

The screw in lower left part of cylinders compartment's door is longer than the others and its removal activates the tamper output. After the screw has been positioned correctly, the machine emits 4 beeps and deactivate tamper output.

This process is useful to discriminate false interpretations of faults caused by electrical shocks or serious problems on power supply from thermal loop problems.

1) Serious fault signal occurs with a first phase when the buzzer emits a continuous sound for 20 minutes and blue led flashes, the output FAULT immediately switch (if the generator is disconnected and connected again you can go directly at point 3)

2) After 20 minutes, the buzzer stops, while blue led goes on flashing, the FAULT output remains closed. This phase remains permanently, until the machine is completely disarmed.

3) When you connect again the machine, blue and red leds flash alternately and no sound is emitted.

This phase lasts for 30 minutes, then, the output FAULT is reset and the generator start to work again.

If during this process the generator is disconnected, when you connect it again the time start again from the beginning and for 30 minutes.

If at the end of this process, the generator start to work again regularly is not necessary any further operation.

If occurs again the fault condition within the following 20 minutes, it's necessary a check from the assistance center, or to send the machine back to the factory.

Checking of the pneumatic circuit and the pressure control system



THE TEST CAN BE DONE JUST BY QUALIFIED PERSONNEL

Before starting the test of the pressure control it's necessary:

- to remove the cylinder
- to be sure that the nozzle is cold
- to be sure that the nozzle tamper pump is activated

The pneumatic seal test must be done within a few seconds when the machine for nozzle tamper control is turned on, as the nozzle temperature rises rapidly reaching temperatures that may cause serious burns.

The air coming out of the nozzle exceeds 200° C.

IT'S ADVISABLE TO USE GLOWES

- 1 – Obstruct the nozzle with soft and insulating material (for example an eraser).
- 2 – Keep the nozzle obstructed, press the button P3 previously moved in RESET position (see paragraph 14) and keep it pressed until you hear that the pump is activated.
- 3 – Wait for the activation of the buzzer (Max 30")
- 4 – Remove the obstruction taking away your hand quickly to avoid to be in contact with the hot emission of air.
The buzzer must stop.
 - If after 30" you don't hear the buzzer, may be a loss inside the circuit; please contact the service center.
 - If after removing the obstruction the buzzer doesn't stop, it means that there is an obstruction; please contact the service center.

7

MAINS POWER AND POWER SUPPLY CONNECTIONS

230V and 110V power source supplies energy only to the heating system. The electronic board and the cylinder's pump are supplied from the alarm system and batteries. The heating element is of 300W, at the very beginning power consumption is about 270W and in some minutes it goes down reaching average consumption is about 37W - 42W.



Do not use inverter or UPS if you are not sure that they generate a true sine wave, not a rebuilt one. Ask please to the UPS manufacturer the correspondance of such features before proceeding with the connection.

- The max current to be considered for the system is 4A
- The connection to the 230V and 110V electricity grid must be performed by a qualified technician.

- Connect the equipment to the electricity grid only after you have completed the installation.
- It is necessary to connect the ground terminal.
- The system must be connected to the mains trough on automatic switch (automatic switch, curie C, with $I_n=10\text{ A}$ and $I_{diff}=30\text{ mA}, \dots$) with breching capacity based on the assumed fault current of the fogging system in the sampling point.

PLEASE NOTE THAT, AS ALL POWERED EQUIPMENT FROM THE ELECTRICITY GRID REQUIRING INSTALLATION, IT IS SUBJECT TO COMPLIANCE WITH RULES OF THE COUNTRY IN WHICH IT IS INSTALLED

For section and types of wires, fuses, suitability of materials to installation sites etc..

IF YOU NEED TO REPLACE THE FUSE, USE ONLY FUSE WITH THE FOLLOWING SPECIFICATIONS:

CERAMIC BODY FILLED WITH QUARTZ, REF. STD. EN60127-2-3/DIN41660 3,15AH (EXAMPLE OMEGA GT520231)

- The battery is necessary to use the system in a safe way. The battery is recharged by power supply coming from J6 PIN + -.
- The placing of the lead-acid battery 2 Ah 12 V is in the case under the heat exchanger.
- In order to accede to the battery case is necessary to remove the frontal cover and the 2 locking screws.
- In case of a brackage of the battery fuse, use exclusively 1 A fuses.

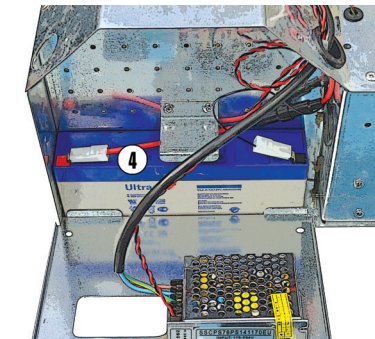
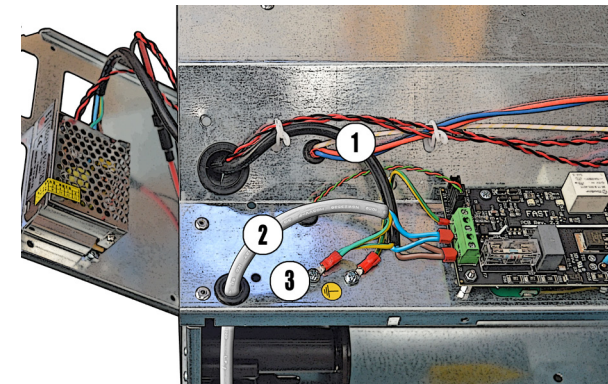

- ① - Power supply mains connections
- ② - Mains power
- ③ - Ground connection
- ④ - Battery holder (battery not included)

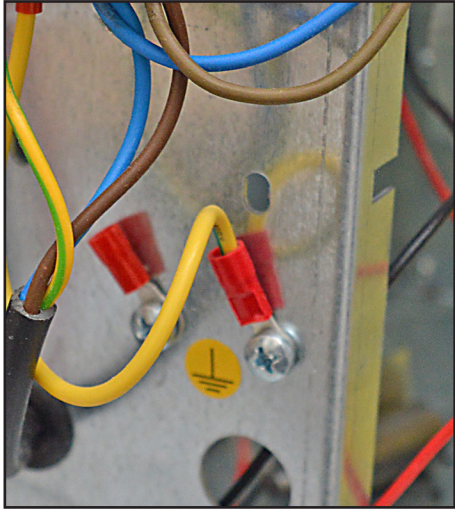

While connecting the machine to the mains power, it is recommended to never disconnect existing ground cable. The fact of disconnecting or modifying existing cables voids the warranty and can cause troubles or accidents related to the temperature control. Connect ground cable from the system to the screw on the metal sheet.

8 DESCRIPTION OF INPUT AND OUTPUT CONNECTIONS

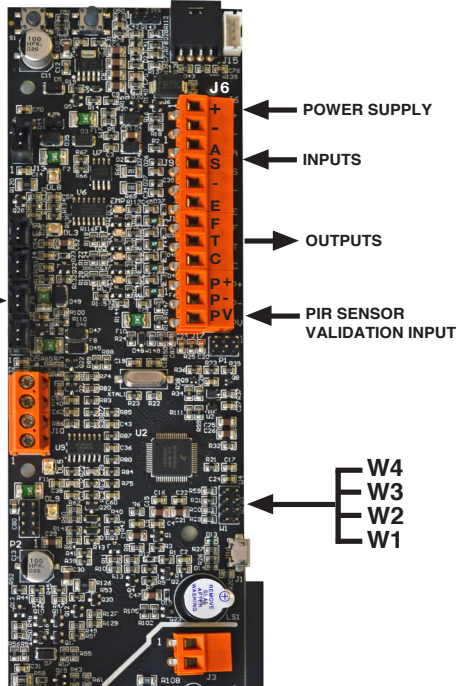

INPUTS

- + Power supply input
- Power supply input
- ARM Arming input
- SHOOT Shooting input
- Negative

OUTPUTS

- EMPTY Empty cylinder output
- FAULT Fault output
- TAMPER Tamper output
- CONFIRM Shot confirmation output

PIR SENSOR VALIDATION INPUT

- P+ Positive power supply output
- P- Negative power supply output / COM. PIR
- PV N.C. PIR

- W4
- W3
- W2
- W1

13 INSTALLATION, EXCHANGE AND CYLINDERS RESET

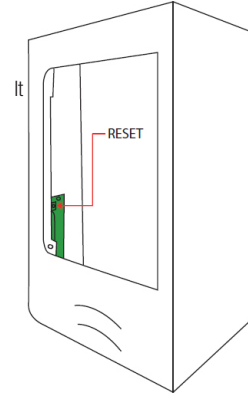

The cylinders for FAST PRO PLUS are guaranteed to work until the expiry date that is printed on the top of them. After that date, cylinders should be changed even if they have not been used. It is recommended to return them to your dealer, who will take care of disposal. After removing the screws of the door, it is sufficient to remove the cylinder and reset the LED of the empty cylinder. After that, insert a new cylinder until you hear the "click" of the plastic support entering in its housing, then close the door.

If the cylinder seems to be "stuck" in the upper part DO NOT pull with force, make a pressure with two fingers on top of the cylinder, as to lower it. Then, try to remove it again. If the cylinder does not enter, check if the cylinder plate of the motor remains lifted.

In case of an empty cylinder to be replaced, it is recommended to replace it with the second cylinder still full present in the machine, and a new cylinder will replace this last one. This is in order to ensure a proper rotation of the cylinders and to avoid that a cylinder can remain unused for a long time within the device.



N.B. When you close the door, the buzzer will make a sound to confirm the tamper is closed. Attention: Before opening the side doors, make sure that the alarm control panel is in "service" mode, so that the opening of the "anti-sabotage or tamper" circuit does not cause any alarm.

14 MAINTENANCE

UR Fog generators do not require special care, however, it is recommended the support of qualified and authorized personnel for periodic annual monitoring, taking into account the following:

- 1- Verify the good working condition of the power supply and battery
- 2- Verify the content and the expiration date of the tanks
- 3- Verify the lock of the nozzle ferrule
- 4- Verify the entirety of the nozzle sphere
- 5- Check the air tightness of the circuit and the switch functioning
- 6- Intervention report redaction and release of conformity declaration according to 37/08 order in case of provision

Check the efficiency of the power supply and of the battery

Verify that the tension of the no-load voltage power supply (disconnected battery) is 13,8 V. If tension is different, regulate it using the trimmer placed on the power supply. Verify the efficiency of the battery (it should not be hot and bloated); it is suggested to change it every two years due to the heavy and prolonged charge during the shot without mains power.

Entirety of the nozzle sphere

Verify that the nozzle hole is cylindrical. The average duration of the nozzle sphere depends on the number and duration of the shooting, around 8L of glycol.

The check of the obstruction of the nozzle is done with a little air flow, while a sensor check the pressure of the internal circuit. In case the sensor detect an increase of the internal pressure, means that there is an obstruction inside the nozzle. As consequence of the detection, if the generator is armed will occur a brief shot of 1 second in order to free the nozzle and to avoid another obstruction.

In the meantime, the output of Tamper will be activated, the buzzer will emit a sound with a fast frequency with the flash of the red LEDs.

This condition of the alarm will continue until the system is disarmed and armed again.

As the little compressor that introduces the air flow emits some vibrations, its activation occurs only in the following cases:

- When you press the button RESET for more than 5 seconds, besides the activations of the drop of the motors, will start a cycle of monitoring of 15 minutes, in order to simulate the obstruction and check the correct working.
- When the system is armed the cycle of monitoring starts. This cycle is the most important, because as the system was disarmed probably was easier to go near the machine and obstruct the nozzle. After 15 minutes, the compressor will stop automatically. If the system is disarmed and armed again, the cycle will start again for 15 minutes.
- After the emission of the fog, as normally the zone where the machine is installed is the last where the visibility is reduced, the generator remains vulnerable, giving the possibility to who generated the alarm to attempt the sabotage. For this reason, after the emission of the fog the compressor will be activated for 15 minutes, and who tries to obstruct the nozzle will cause a shot.

As the little compressor that introduces the air flow emits some vibrations, its activation occurs only in the following cases:

- When you press the button RESET for more than 5 seconds, besides the activations of the drop of the motors, will start a cycle of monitoring of 15 minutes, in order to simulate the obstruction and check the correct working.
- When the system is armed the cycle of monitoring starts. This cycle is the most important, because as the system was disarmed probably was easier to go near the machine and obstruct the nozzle. After 15 minutes, the compressor will stop automatically. If the system is disarmed and armed again, the cycle will start again for 15 minutes.
- After the emission of the fog, as normally the zone where the machine is installed is the last where the visibility is reduced, the generator remains vulnerable, giving the possibility to who generated the alarm to attempt the sabotage. For this reason, after the emission of the fog the compressor will be activated for 15 minutes, and who tries to obstruct the nozzle will cause a shot.



Do not obstruct the nozzle when the generator is armed and cylinders are in, the shot can cause hurts and burns.



If the nozzle is obstructed, even if the emission of the fog removes the obstruction, it is necessary to check that the pneumatic circuit is not damaged. See paragraph 16 In some cases is necessary to let the system be checked by the service center.

INPUTS

+ 12V Power input

The power supply is connected to those inputs.

INPUT SIGNALS

A By connecting this input to positive, FAST PRO PLUS is armed, blue frontal LED is switched on and when the machine reaches proper temperature it means that it is ready for shooting.

S Putting this input to positive, if FAST PRO PLUS is hot and armed, starts fog emission for the set time. In case of alarm, opening ARM input, the fog emission stops immediately, even if the time set wasn't reached.

VALIDATION INPUT

In order to validate this input, it's necessary to insert the jumper W4. This input automatically generates AND function with input S. If any input receives the shooting command, the generator doesn't emit fog if within 1 minute doesn't receive the command also from the second input.

P+ Output positive to give power to a validation sensor or a remote control receiver, max 300 mA.

P- Output negative to give power to a validation sensor or a remote control receiver, max 300 mA.

PV Validation input. It's possible to connect to this input a validation sensor with a contact normally closed connected to the terminal P-.

In order to check the correct operation of PV input, it's necessary to remove the jumper W4.

When AND function is disabled, to each opening of PV input you will hear a "beep" for 5". At the end of the test, re-establish AND function inserting jumper W4 again.

OUTPUTS

E This output (NPN Open Collector) closes towards negative direction when the cylinder is empty. This output (NPN open collector) closes towards negative when the fogging machine emitted fog for at least 100" or when the cylinder is empty. The signal is activated by a sensor that detects the absence of liquid just while shooting.

The empty cylinder signal is deactivated only making the RESET (see paragraph 13). For this reasons, if the cylinder is not inserted, or there is an empty cylinder inside, FAST PRO PLUS will detect it just after a shot.

F This output (NPN Open Collector) closes towards negative when there is a malfunction (such as batteries expired, fault of power supply or temperature control fault), which compromises the functioning of the device and which requires a technical action.

Fault signal due to supply absence has a delay of 20 minutes.

T This output (NPN Open Collector) closes towards negative direction when you open the cylinder door or when the accelerometer detects a sudden movement (such as the detachment from the wall).

C This output (NPN open collector) closes towards negative only after that the system has emitted fog for the set time. If the emission of fog is interrupted (if there is an interruption of ARM command, if the glycol finishes, if there is not thermal autonomy anymore) this output will not change its status.



Remember, it is necessary to connect all three outputs to an alarm central or an electronic panel that can see all those information in real time and take proper action.

In order to avoid accidental activation with subsequent fog emission, the inputs are in "negative security", for this reason the disconnection of a wire does not cause activation.

So it is necessary to check carefully the reliability of connections and protect the cables to the control panel to avoid the risk of accidental damages.

JUMPER W4: if closed, it activates external PIR.

JUMPER W3: reserved for diagnostic, DO NOT USE!

JUMPER W2: if closed, it activates antirobbery function (instant shot through antirobbery button).

JUMPER W1: if closed, it activates the serial port to use additional boards, like LAN board (not relay board).



The diagrams and examples below are intended only for a “better understanding” of the operation of the inputs / outputs. None of the diagrams below represents the “single scheme to perform” as, in respect of the reference standard EN50131-8, there are precise indications and only using all inputs and outputs on the PCB it is possible to abide by the standard.



For safety reasons and to avoid false fog emissions, after arming, FAST PRO PLUS becomes operative only after 20 “. After this time , fog emission is immediate.

- A Example of connection of FAST PRO PLUS inputs with outputs of a standard alarm system
- B Example of connection of FAST PRO PLUS inputs to an alarm with relay outputs
- C Example of connection of FAST PRO PLUS inputs with outputs of an alarm with open collector outputs
- D Example of connection of FAST PRO PLUS outputs to drive LEDs and / or relays
- E Example of connection of FAST PRO PLUS outputs with inputs of an alarm normally opened
- F Example of connection of FAST PRO PLUS outputs with balanced inputs of an antitheft
- G Example of connection of FAST PRO PLUS outputs with antirobbery connection.
- H Example of connection of FAST PRO PLUS outputs with relay board.

A - Example of connection of FAST PRO PLUS inputs with outputs of a standard alarm system

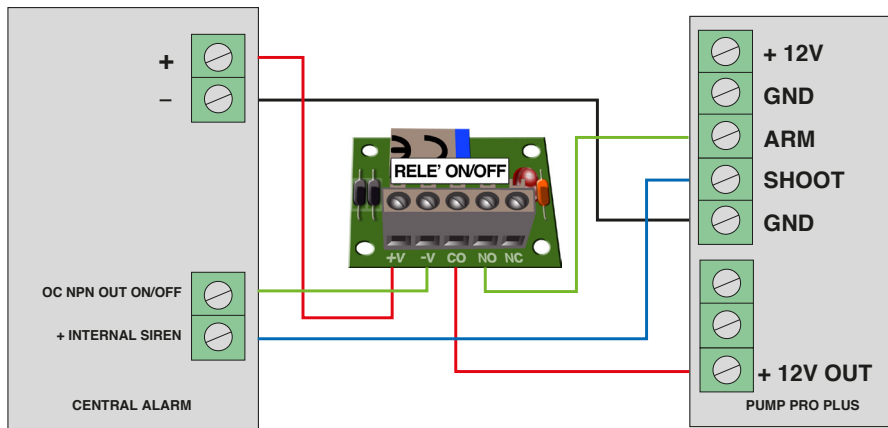

In the diagram above the control panel, as example, provides to UR Fog power supply between 11 and 14V DC 250 mA max. The ON/OFF output of this alarm is an Open Collector NPN opened when the system is off and it is stably closed to negative as long as the system turned on. The alarm output of the alarm is normally open and becomes positive during the alarm time.

N.B. To correctly dimension the machines it is needed to verify that the saturation of the area occurs in faster time than the one supposed for the theft.

SHOOTING TABLE FAST 03 PRO PLUS (2C and 1C)

m³ to protect	Seconds of emission	m³ to protect	Seconds of emission	m³ to protect	Seconds of emission
15 - 18	1	87 - 105	6	160 -192	11
29 - 35	2	102 - 122	7	175 - 210	12
44 - 52	3	116 - 140	8	189 - 227	13
58 - 70	4	131 - 157	9	204 - 244	14
73 - 87	5	146 - 175	10	218 - 262	15

SHOOTING TABLE FAST 02 PRO PLUS

m³ to protect	Seconds of emission	m³ to protect	Seconds of emission	m³ to protect	Seconds of emission
19-23	1	190-228	10	325-390	19
38-46	2	205-246	11	340-408	20
57-68	3	220-264	12	355-426	21
77-92	4	235-282	13	370-444	22
96-115	5	250-300	14	385-462	23
115-138	6	265-318	15	400-480	24
135-162	7	280-336	16	415-498	25
160-192	8	295-354	17		
175-210	9	310-372	18		

The value in the first column indicates the volume of the room to be protected, with respective seconds of emission reported in the second column. The value in m³ varies depending on the density to be obtained. Within the second column, the first value allows to get the maximum density recommended to ensure the absence of any residual, while with the second value you get minimum recommended visibility of according to the standard CENELEC, whereas a higher visibility would make the fog superfluous. In places where a little residual causes no problems, it is possible to increase the shooting time. Please note that the higher the fog released, the more the time required to recover visibility. High levels of fog, over recommended limits, can leave residual.

Any residue usually goes away by itself within 24/48 hours, otherwise, being soluble in water, it is enough to use a wet cloth for cleaning.

If you desire to obtain an average of 1 meter visibility after 60 seconds, as specified by the standard, as used as reference by all manufacturers of Fog generators, the number of shooting seconds must be doubled.

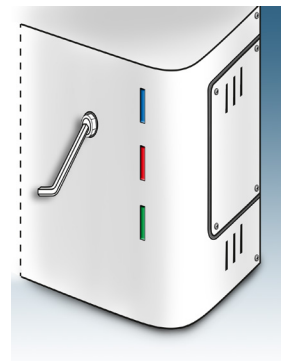

FOG FLOW DIRECTION

To ensure the right direction of the fog flow, it is recommended to insert a screwdriver of the diameter of the hole and, without forcing, orient the nozzle in the correct fog emission direction.

This allows you to clearly see the direction and keep it in place while tightening.

To screw and unscrew the nozzle you should use a pair of pliers in good condition to avoid damaging the plating.

Do not overscrew the nozzle, it is sufficient that the teflon nozzle does not move.

Do not direct the fog jet towards objects and walls less than 2 meters away or to the floor if it is installed at a height lower than 2.50 meters (we advise against the installation on the floor).



WARNING! After the fog emission, and for a few minutes the nozzle is very hot RISK OF BURNS IF TOUCHED by bare hands.

ARM
FAULT

BLUE LED

When on it means the machine is armed and, if hot, it's ready to shoot.
When flashing means something is wrong.
(See paragraph 16 "DEFECTS AND POSSIBLE SOLUTIONS")

EMPTY
RESERVE

RED LED

When on when at least one cylinder is empty or it is in reserve (only 1C model)
(See paragraph 13 INSTALLATION, EXCHANGE AND CYLINDERS RESET)

HEATING

GREEN LED

When on (steady green light) means the machine is hot and ready for the fog emission.
When flashing means the heating process is in progress.
In this step the machine is heating but is not ready to shoot.



IF THE BLUE LED IS FLASHING, TOGETHER WITH A CONTINUOUS SOUND FROM THE BUZZER, A SERIOUS PROBLEM IS DETECTED. SEE PARAGRAPH 15

The symbol of empty cylinder, in **03 1C MODEL** has the meaning of "RESERVE"

11 SHOOTING TIME SETTING AND FOG FLOW DIRECTION

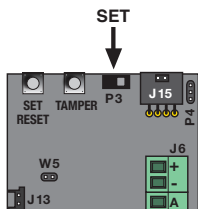

To set the shooting time, after opening the cylinders compartment door, at the top of the PCB, facing the board you must move the jumper in left position P3 (closer to the buttons S1/S2). Then, holding down the button S1 "SET", 6 leds on the front will flash and each flash is equivalent to one second. If you press the button again, the shooting time is not added to the one previously set, but will restart from zero.

N.B. Before opening side door ensure that the control panel is set to "service", so that the opening of "anti-sabotage or tamper" circuit does not cause any shooting.

RECOMMENDED SHOOTING SECONDS ACCORDING TO THE VOLUME SPACE TO PROTECT (m³)

Fogging systems FAST 03 PRO PLUS and FAST 02 PRO PLUS are able to produce fog for a maximum respectively 15 and 25 seconds per single shot. The maximum quantity of 9,7 ml/s (FAST03 PRO PLUS) and 12,8 ml/s (FAST 02 PRO PLUS) allows to fill an area of about 200 and 400 m³.

There might be cases in which, due to specific characteristic of the location, nozzle type, levels of temperature and air pressure, degree of the fog density and light in the target area, the shooting time can be increased or decreased. For example, above 5 m of height the shooting time must be integrated and above 7 m, every additional meter should be considered as double.

$$(H \times L \times P) \times D \times V \times R \times I$$

- HxLxP-----Height x Width x Depth of the area to protect
- D-----Density of the produced fog
- V-----Temperature and air pressure
- R-----Acceptable residue in case of saturation of V parameter
- I-----Intensity of the surface light

The following tables indicate the suggested fog emission in relation to the number of seconds of shooting set in average condition of temperature, air pressure and humidity.

B - Example of connection of FAST PRO PLUS inputs to an alarm with relay outputs

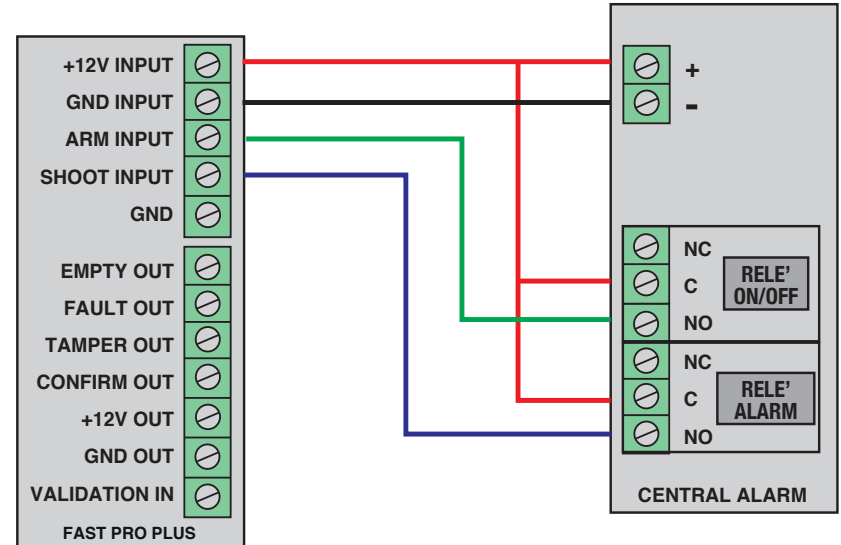

ON/OFF output of this alarm central is an open relay when the system is off and it is stably closed to positive as long as the system is turn on.

C - Example of connection of FAST PRO PLUS inputs with outputs of an alarm with open collector outputs

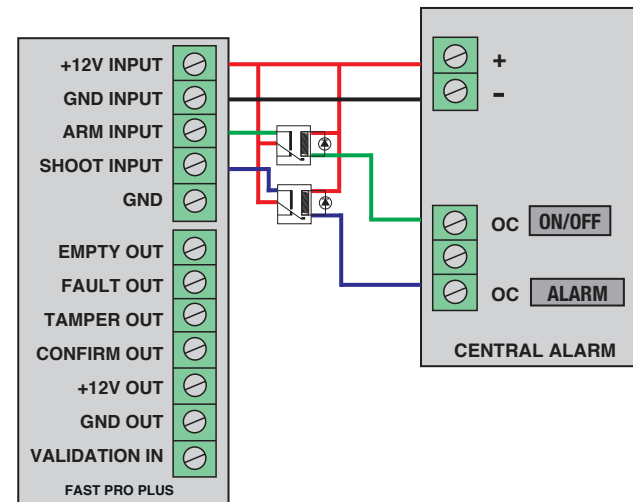

Compared to B diagram, this alarm central has only open collector outputs. The simplest action to take is to use 2 relays to create a connection similar to the one shown in the previous diagram.

D - Example of connection of FAST PRO PLUS outputs to drive LEDs and / or relays

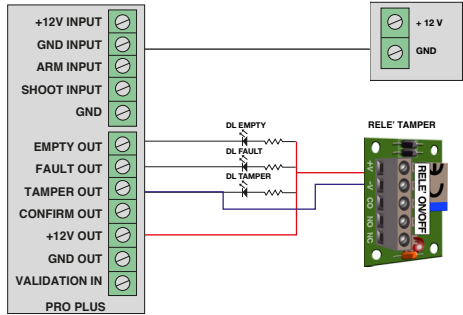

In case of an empty cylinder, the DL EMPTY LED will switch on.
 In case of a fault, the DL FAULT LED will switch on.
 By opening the cylinders door, besides the DL TAMPER turning on, the relay will switch as well.
Max power applicable on the outputs is 100mA

E - Example of connection of FAST PRO PLUS outputs with inputs of an alarm normally opened

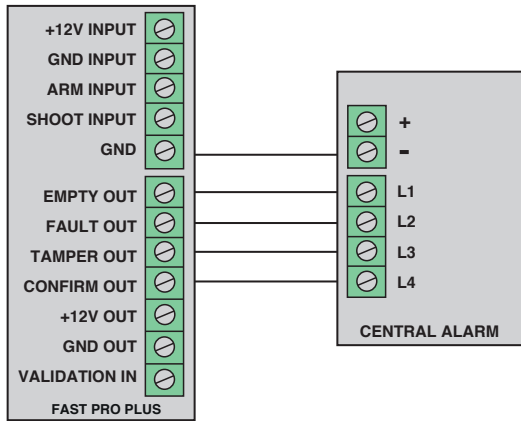

The outputs shown in the diagram are not always necessary, but only in cases where the voltage of pull-up resistance is lower than that of power supply.

The UR Fog outputs are normally opened and connected with input zones of the alarm control panel normally opened.

F - Example of connection of FAST PRO PLUS outputs with balanced inputs of an antitheft

In this diagram, by putting a resistance with a value required by the alarm control panel used, in UR Fog terminal with not used outputs the central will see the correct resistance. After the activation of an output, a pull-down will occur causing the alarm in the corresponding zone.

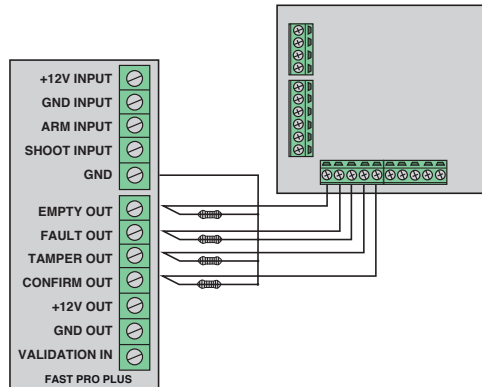

G - Example of connection of FAST PRO PLUS outputs with antirobbery connection.

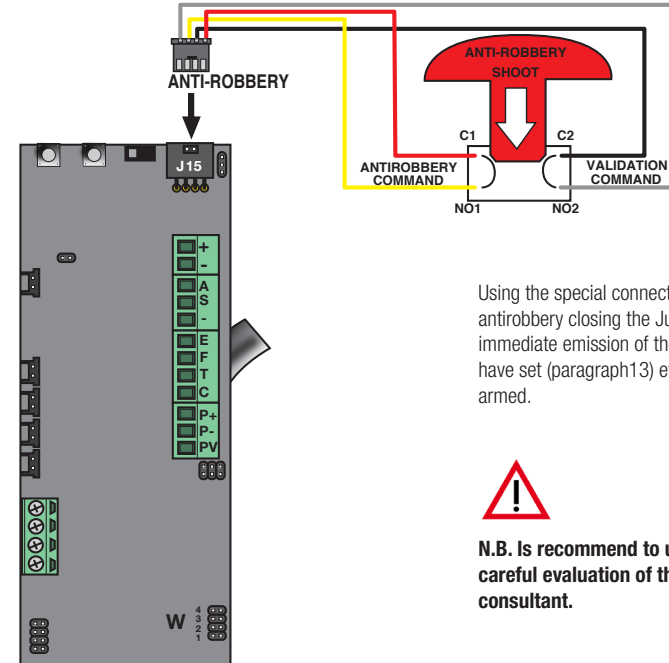

Using the special connector and enabling the option antirobbery closing the Jumper W2, you will obtain the immediate emission of the fog for the seconds that you have set (paragraph13) even if the fogging system is not armed.



N.B. Is recommend to use this function after a careful evaluation of the risks from a security consultant.

H - Example of connection of FAST PRO PLUS outputs with relay board.

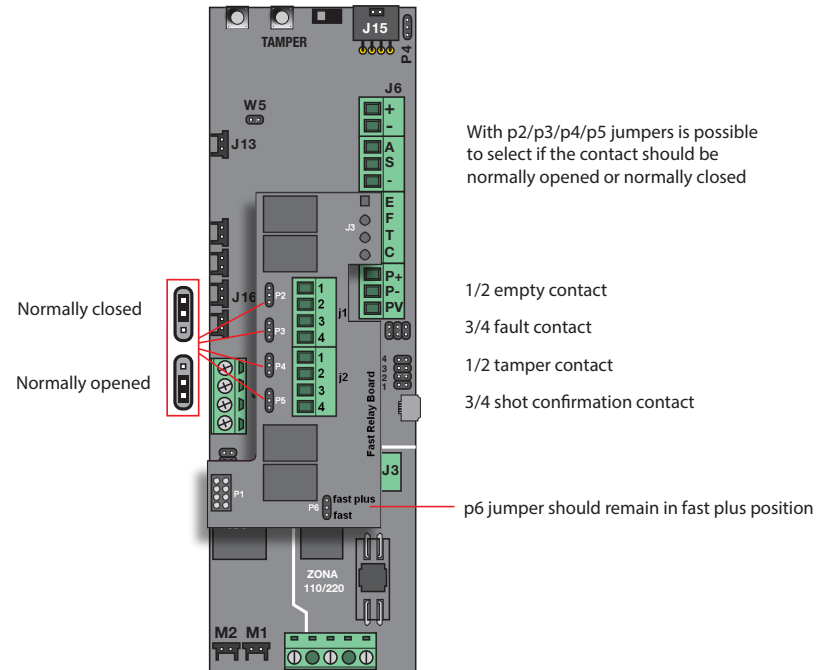

With p2/p3/p4/p5 jumpers is possible to select if the contact should be normally opened or normally closed